

2x1 18G KVM Extender over HDBaseT User Operation Guide



HDBT-HUUB321-70M
RX



HDBT-HUUB321-70M
TX

Model:

HDBT-HUUB321-70M

User Operation Guide

OVERVIEW

The ABtUS 2x1 18G KVM Extender over HDBaseT includes a transmitter (TX) and a receiver (RX), enabling high-quality video transmission over a single CAT6A cable. It supports distances of up to 40m at 4K@60Hz and 70m at 4K@30Hz. Additional features include audio pass-through, two-way IR, USB extension, and RS232 pass-through. The 24V PoC (Power over Cable) functionality allows the TX and RX to power each other, requiring only one power adapter for the entire system— either the TX or RX needs to be powered.

PRODUCT FEATURES

- 18Gbps high bandwidth, HDMI V2.0.
- HDMI and USB-C video resolution up to 4K@60Hz 4:4:4, HDR10, Dolby Vision.
- Supports to transmit up to 40m at 4K@60Hz or 70m at 4K@30Hz, with HDCP 2.2.
- Controlled by button on the front panel, GUI (via TCP/IP) and RS232.
- Two-way IR and RS232 pass-through.
- Supports audio separation for PCM 2.0, and audio pass-through.
- Supports two-way 24V PoC.
- Provides HDMI loop out.

PANEL DESCRIPTIONS

Transmitter Panel (Front)

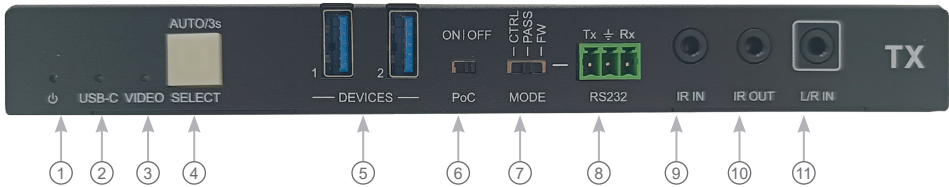

1. **POWER LED:** Illuminates green when power is applied.
2. **USB-C LED:** Illuminates when USB-C is selected to be the video input source.
3. **VIDEO LED:** Illuminates when HDMI (VIDEO port) is selected to be the video input source.
4. **SELECT Button:** Switch video input source from either USB-C or HDMI.
5. **DEVICES:** Two USB3.2 Gen1 Type-A ports, provide 500mA shared current in total.
6. **PoC:** DIP switch for PoC ON/OFF.
7. **MODE:** DIP switch for RS232 mode selection.
 - CTRL: Execute commands locally that is sent to the
 - PASS: RS232 pass-through.
 - FW: Firmware upgrade.
8. **RS232:** 3-pin Phoenix socket, used for control, pass-through or upgrading.
9. **IR IN:** Connects to the IR receiver for IR pass-through.
10. **IR OUT:** Connects to the IR emitter for IR pass-through.
11. **L/R IN:** 3.5mm jack for audio input.

User Operation Guide

PANEL DESCRIPTIONS

Transmitter Panel (Rear)

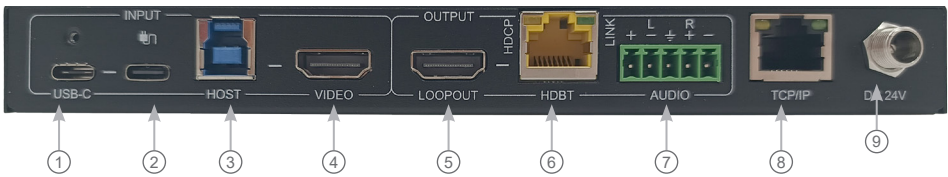

- 1. USB-C IN:** USB Type-C with charging capability to connect the source device.
- 2. Power:** USB Type-C connect to external PD PSU to charge USB-C IN.
- 3. HOST:** USB3.2 Gen1 Type-B port for PC connection. The PC can be controlled by the USB devices which are connected to the HOST port of transmitter.
- 4. VIDEO:** Connects to HDMI source device.
- 5. LOOPOUT:** Connects to HDMI display device.
- 6. HDBT OUT:** RJ45 port to connect the HDBT output port of receiver by CAT6A Ethernet cable. The LINK LED (green LED) illuminates when there is a valid HDBaseT link between the transmitter and the receiver. The HDCP LED (yellow LED) illuminates when the video contains HDCP content, and the HDCP LED flashes when there is no HDCP.
- 7. AUDIO:** 5-pin terminal block for balanced audio output.
- 8. TCP/IP:** 1 x RJ45 port for GUI control.
- 9. DC 24V:** DC barrel port for power adapter connection.

PANEL DESCRIPTIONS

Receiver Panel (Front)

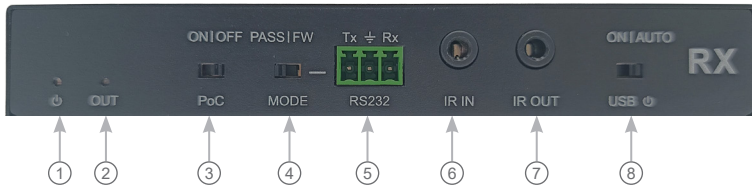

1. **POWER LED:** Illuminates green when power is applied, yellow and green lights flash alternately when the current is too high. (When over the total current limitation for USB devices).
2. **OUT LED:** Illuminates when there is a HDMI display device is connected to HDMI output port and when input source is detected.
3. **PoC:** DIP switch for PoC ON/OFF
4. **MODE:** DIP switch for RS232 mode selection.
PASS: RS232 pass-through.
FW: Firmware upgrade.
5. **RS232:** 3-pin Phoenix socket, used for upgrading or pass-through.
6. **IR IN:** Connects to the IR receiver for IR pass-through.
7. **IR OUT:** Connects to the IR emitter for IR pass-through.
8. **USB POWER:** DIP switch for USB power management.
ON: USB device ports output power all the time;
AUTO(Default): Follow Host, USB device ports will only output power when a host is active connected.

User Operation Guide

PANEL DESCRIPTIONS

Receiver Panel (Rear)

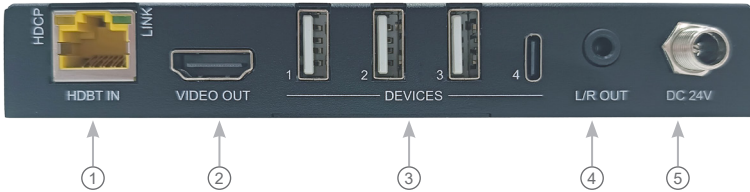

- 1. HDBT IN:** RJ45 port to connect the HDBT input port of receiver by CAT6A Ethernet cable. The LINK LED (green LED) illuminates when there is a valid HDBaseT link between the transmitter and the receiver. The HDCP LED (yellow LED) illuminates when the video contains HDCP content, and the HDCP LED flashes when there is no HDCP.
- 2. VIDEO OUT:** Connects to HDMI display device.
- 3. DEVICE:** 3x type-A USB 2.0 ports and 1x type-C USB 2.0 port share 2A for USB devices (e.g. Mouse, Keyboard and Camera) connection to control the PC which is connected to the HOST port of receiver.
- 4. L/R OUT:** 3.5mm jack for audio output.
- 5. DC 24V:** DC connector for the power adapter connection.

SYSTEM OPERATIONS

Button Control

Manual Switching

When the switcher is in the manual switching mode, press the **SELECT AUTO/3s** button repeatedly to cycle through the two video inputs, and the corresponding source LED illuminates blue immediately.

Automatic Switching

Press and hold the **SELECT AUTO/3s** button at least 3 seconds to enable automatic switching.

In the AUTO mode, the extender would react to below scenarios:

- Press and hold the **SELECT AUTO/3s** button at least three seconds again will exit AUTO mode.
- **New input:** Once detecting a new input, the switcher will automatically select the new input.
- **Reboot:** Once power is restored to the switcher, it will automatically reconnect the input before powered off.
- **Source removed:** When an active source is removed, the switcher will switch to the other active input.

User Operation Guide

SYSTEM OPERATIONS

GUI Control

Login

The Extender also be controlled via TCP/IP port on the transmitter. The default IP settings are:

IP Address: 192.168.0.178

Subnet Mask: 255.255.255.0

Gateway: 192.168.0.1

Telnet Port: 4001

Type **192.168.0.178** in the internet browser, it will enter the below log-in webpage:

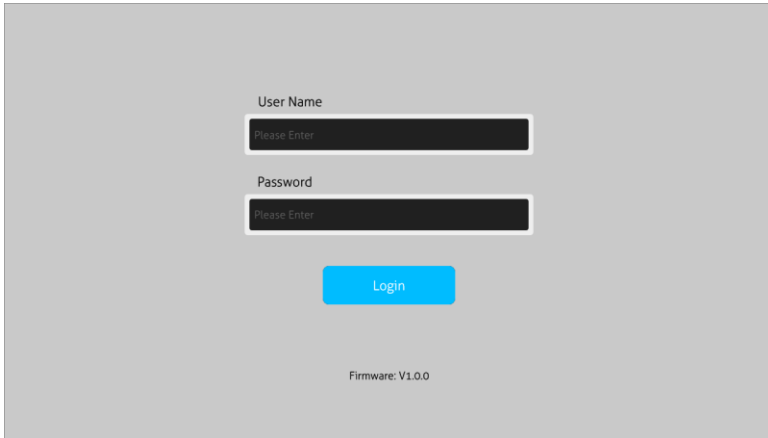

The screenshot shows a login interface with a light gray background. At the top, there is a label "User Name" above a dark gray input field containing the placeholder text "Please Enter". Below this is a label "Password" above another dark gray input field with the same placeholder text. A bright blue button with the text "Login" is centered below the input fields. At the bottom of the page, the text "Firmware: V1.0.0" is displayed.

User Name: admin

Password: admin

Enter the username and password into the respective input fields, then click the **Login** button.

SYSTEM OPERATIONS

Control Tab

Selection of Video Input Source

Select a video input source from either USB-C or Video (HDMI port).

USB-C: Select the video input source as USB-C.

Video (HDMI port): Select the video input source as Video.

Auto: In this mode, it will automatically switch to the new connection source or the one that is just been powered on. When the currently active source loses power or is disconnected, it will seamlessly switch to another input source with active signal.

Also, when the transmitter restarts, it will remember the last connected video input source automatically.

Audio De-embedding Switch

Enable/disable the output of the 5-pin terminal block.

ON: Enable audio output from the 5-pin terminal block.

OFF: Disable audio output from the 5-pin terminal block.

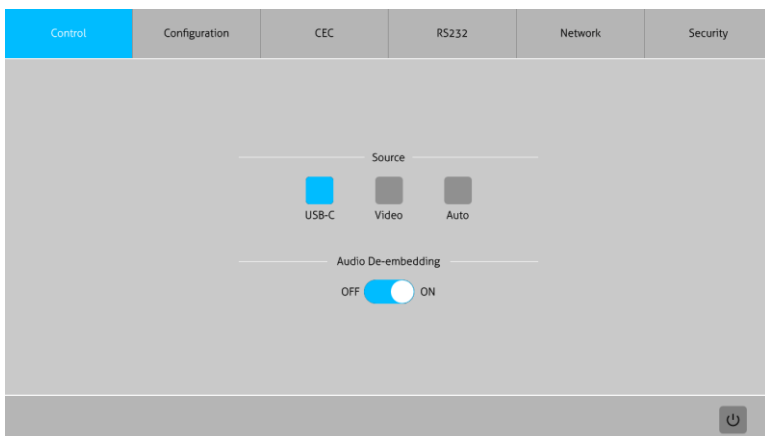

User Operation Guide

SYSTEM OPERATIONS

Configuration Tab

EDID Settings

Choose the desired EDID format or define the appropriate EDID format.

- **Pass Through: Tx**

Retrieve the EDID of the screen connected to the VIDEO port on the TX, then provide it to the video source. This will ensure that the image on the screen connected to the RX is adjusted to match the screen connected to the TX.

- **Pass Through: Rx**

Retrieve the EDID of the screen connected to the VIDEO OUT port on the RX, then provide it to the video source. This will ensure that the image on the screen connected to the TX is adjusted to match the screen connected to the RX.

- **Built-in EDID:** There are 7 built-in EDID values can be selected by this tab.

- **User-defined EDID:** There are four EDID values can be customized by the below steps:

Step 1: Prepare the EDID file (.bin) on the control PC.

Step 2: Select the user-defined.

Step 3: Click the black box , and then select the EDID file (.bin) according the tooltip.

Step 4: Click **Apply** to upload the user-defined EDID.

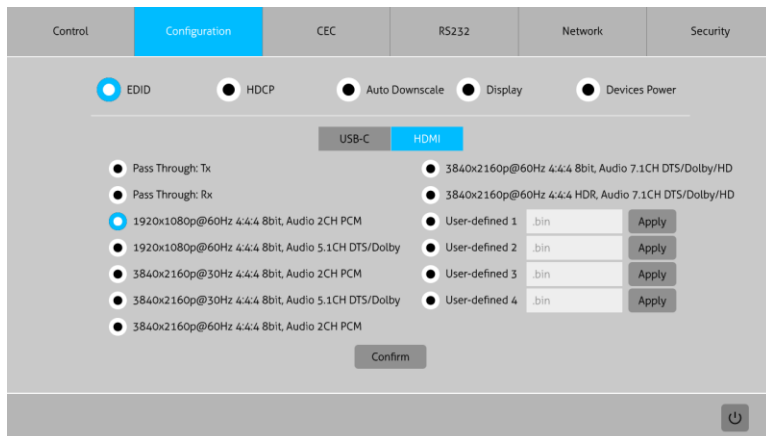

SYSTEM OPERATIONS

HDCP Settings

Select an HDCP mode.

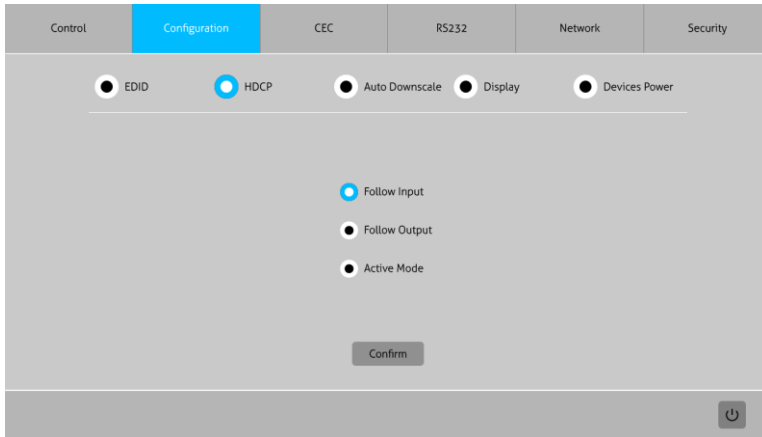

Auto Downscale

Enable: When the resolution of the display is lower than video input source, the resolution will automatically be downscaled to 1080p.

This feature enables the screen to at least show a relative low-resolution image instead of a blank screen.

Disable: Disable auto downscale feature.

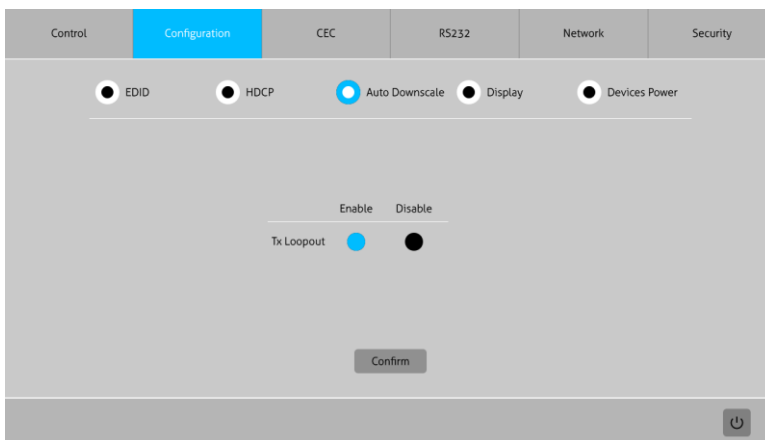

User Operation Guide

SYSTEM OPERATIONS

Display

Auto CEC Trigger: When the TX is turned on, it sends a CEC command to the display connected to the RX to power it on. If no signal is detected from the source, another CEC command is sent to turn off the display.

Display On with Power: When the TX is turned on, it sends an RS-232 command to the display connected to the RX to power it on. If no signal is detected from the source, another RS-232 command is sent to turn off the display.

The screenshot shows the Configuration menu with the following settings:

- Control: Configuration (selected), CEC, RS232, Network, Security
- EDID:
- HDCP:
- Auto Downscale:
- Display:
- Devices Power:
- Auto CEC Trigger:
- Display On with Power:
- Time(s):
 - Display Off Delay: 600 (Range 1 - 600) [Save]
- RS232ONSAVE:
 - Baudrate: 9600
 - Command: xxxxxxxxxxxx
 - Command Ending: NULL [Save]
- RS232OFFSAVE:
 - Baudrate: 9600
 - Command: xxxxxxxxxxxx
 - Command Ending: NULL [Save]
- Power button:

SYSTEM OPERATIONS

Devices Power

Follow Host: Whether or not the DEVICES ports would be powered is depend on whether or not the HOST device is connected.

Always On: There will always power be provided to the devices connected to the DEVICES ports, even though the device connected to HOST port is powered off.

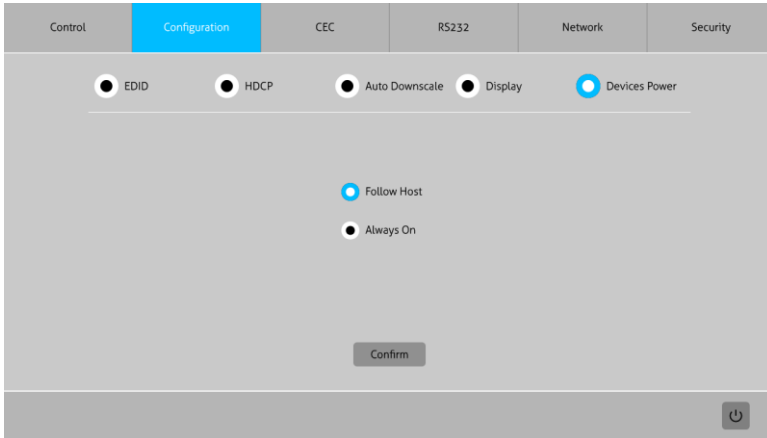

User Operation Guide

SYSTEM OPERATIONS

CEC Tab

If the input source devices and HDBaseT output devices support CEC, they can be controlled via the following CEC interface.

1) Input Source Device Control

Select the input source from USB-C or Video that need to be controlled, then press the function button at the right side.

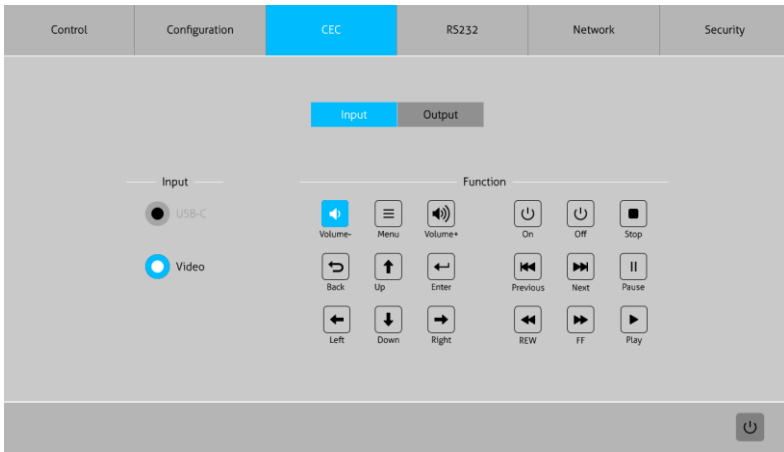

2) Output Device Control

Select the output source from Tx Loopout or Rx Output that need to be controlled, then press the function button at the right side.

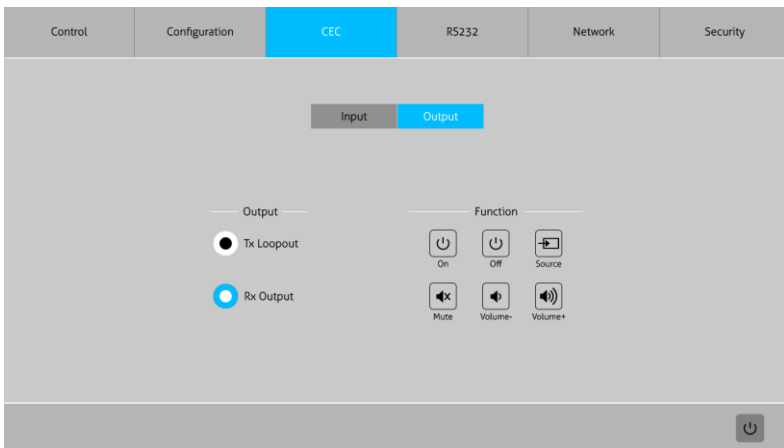

SYSTEM OPERATIONS

RS232 Tab

Baud Rate: Supports 2400, 4800, 9600, 19200, 38400, 57600, 115200.

Command Ending: NULL, CR, LF or CR+LF can be chosen.

Command: Type the command in the box to control the third-party device which is connected to the RS232 port of the HDBT-HUUB321-70M.

The screenshot shows the RS232 configuration tab. At the top, there are navigation tabs: Control, Configuration, CEC, RS232 (highlighted in blue), Network, and Security. The main area contains the following settings:

- Mode: ASCII, HEX
- Baud Rate: 9600 (dropdown menu)
- Command Ending: NULL (dropdown menu)
- Command: (text input field)

At the bottom, there are two buttons: "Confirm" and "Cancel". A power icon is visible in the bottom right corner of the interface.

Network Tab

Toggle either Static IP or DHCP (Dynamic Host Configuration Protocol).

DHCP: The device will automatically generate the IP Address, Subnet Mask and Gateway.

Static IP: Manually modify the static IP Address, Subnet Mask, and Gateway.

The screenshot shows the Network configuration tab. At the top, there are navigation tabs: Control, Configuration, CEC, RS232, Network (highlighted in blue), and Security. The main area contains the following settings:

- MAC Address: 44-33-4C-C9-35-12
- DHCP: DHCP, Static IP
- IP Address: 192.168.0.178 (text input field)
- Subnet Mask: 255.255.255.0 (text input field)
- Gateway: 192.168.0.1 (text input field)

At the bottom, there is a "Confirm" button. A power icon is visible in the bottom right corner of the interface.

User Operation Guide

SYSTEM OPERATIONS

Security Tab

In this tab, you can change the login password, upgrade the firmware, lock the Front Panel and factory reset the device.

- Password: Modify the GUI login password;
- Choose the firmware upgrade file and click confirm to upgrade the firmware;
- Lock or unlock the front panel buttons;
- Factory Default reset.

The screenshot shows the Security Tab interface with the following elements:

- Navigation Tabs:** Control, Configuration, CEC, RS232, Network, and Security (highlighted in blue).
- Password:** A text input field containing "admin" and a "Confirm" button.
- Firmware Upgrade:** A text input field containing "C:\\" and a "Confirm" button.
- Front Panel Lock:** A toggle switch currently in the "ON" position (blue).
- Auto Standby:** A toggle switch currently in the "ON" position (blue).
- Auto Standby Duration:** A text input field containing "10" followed by "mins" and a "Confirm" button.
- Factory Default:** A grey square button.
- Power Button:** A power icon button located in the bottom right corner.

SYSTEM OPERATIONS

RS232 Control

Connect the control device (PC) to the RS232 port of the transmitter, it can be controlled by sending RS232 commands via RS232 control software installed in PC.

The RS232 port also supports pass-through function, in addition, RS232 commands can be transmitted bi-directionally between the transmitter and receiver, so it is able to control a third-party device from local or remote. The baud rate supports 2400, 4800, 9600(default), 19200, 38400, 57600 or 115200.

RS232 Control Software

- **Installation:** Copy the control software file to the computer connected with the transmitter.
- **Uninstallation:** Delete all the software files in corresponding file path.
- **Basic Settings:**

First to connect transmitter with all input devices and output devices needed, then to connect it with a computer which is installed with RS232 control software. Finally, double-click the software icon to run this software.

Here we take the software **CommWatch.exe** as example. The icon is showed as below:



CommWatch.exe

User Operation Guide

SYSTEM OPERATIONS

The interface of the control software is showed as below:

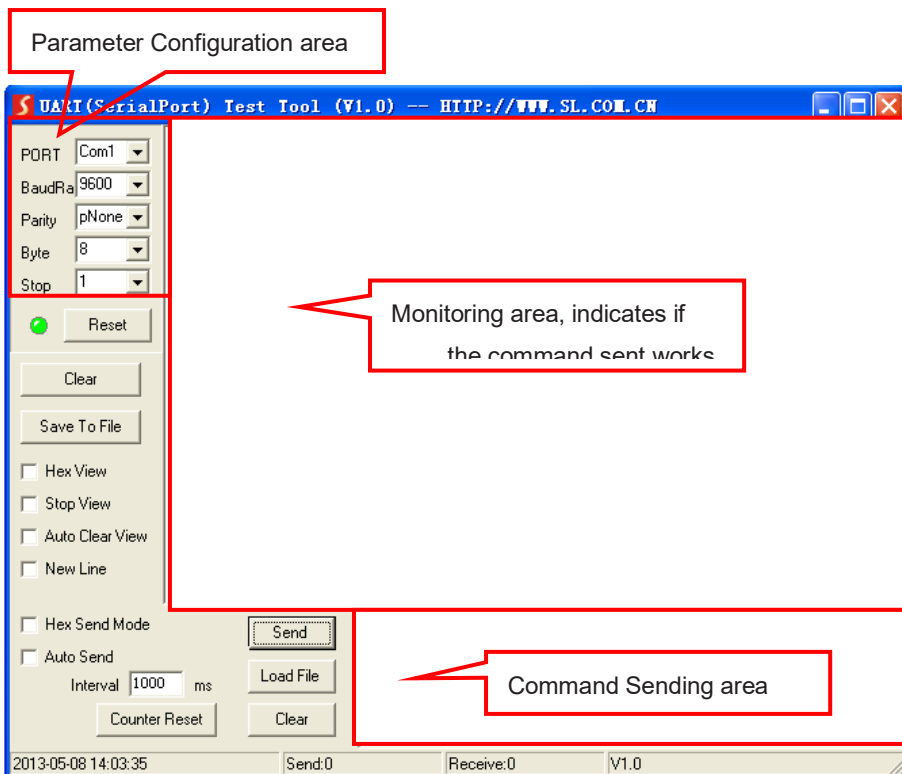

Please set the parameters of COM number, bound rate, data bit, stop bit and the parity bit correctly, and then the command is ready to be sent in Command Sending Area.

SYSTEM OPERATIONS

RS232 Command

Communication protocol: RS232 Communication Protocol

Baud rate: 9600

Data bit: 8

Stop bit: 1

Parity bit: none

STA.	Report system status.	<p>HDBT-HUUB321-70M 2x1 18G KVM Extender over HDBaseT 3.0 FW Version: V1.0.0a Power On! Front Panel Unlock! Local RS232 Baudrate Is 9600! MAC:50-2E-AB-0C-DE-7C! GUI IP DHCP:OFF! GUI_IP:192.168.0.178! GUI_SM:255.255.255.0! GUI_GW:192.168.0.1! HDMI Out Switch Auto Mode! HDMI Out Switch To 01! Input 01 EDID From 03 EDID! Input 02 EDID From 03 EDID! Out HDCP Follow Output! Tx Loopout Down Scale On! Trigger Mode Is 5V! Audio De-embedding On! Device Power Mode Is Follow Host!</p>
RST.	Factory reset.	Factory Default!
Baudrate[x].	Set baud rate to [x]. [x] can be 2400, 4800, 9600, 19200, 38400, 57600, or 115200.	Example: Baudrate9600. Feedback: Set Local RS232 Baudrate To 9600!
POWON.	Power on system.	Power On!
POWOFF.	System standby.	Power Off!
HDMI[x].	Select X as the video input source. [X] can be 1-2.	HDMI Out Switch To 01!
HDMIA.	Enable Auto-Switch Mode.	HDMI Out Switch Auto Mode!
HDMIM.	Enable Manual Switch Mode.	HDMI Out Switch Manual Mode!
AOUTON.	Turn on the audio de-embedding.	Audio De-embedding On!
AOUTOFF.	Turn off the audio de-embedding.	Audio De-embedding Off!

User Operation Guide

SYSTEM OPERATIONS

<p>EDID/[XX]/[YY].</p>	<p>Render the video source that connected to the [XX] port on the transmitter to use the EDID of [YY].</p> <p>[XX] represents the video input port. 00: represents all the input ports. 01: represents No. 1 video input port. 02: represents No. 2 video input port.</p> <p>[YY] represents the included EDID as below: 01: Use the EDID of the screen that connect to the transmitter (TX). 02: Use the EDID of the screen that connected to the receiver (RX). 03:1920x1080@60 8bit Stereo (default) 04:1920x1080@60 8bit High Definition Audio 05:3840x2160@30Hz 8bit Stereo Audio 06:3840x2160@30Hz Deep Color High Definition Audio 07:3840x2160@60Hz 4:2:0 Deep Color Stereo Audio 08:3840x2160@60Hz Deep Color Stereo Audio 09:3840x2160@60Hz Deep Color High Definition Audio 10:3840x2160@60Hz Deep Color HDR LPCM 6CH 11: User-defined EDID1 12: User-defined EDID2 13: User-defined EDID3 14: User-defined EDID4</p>	<p>Example: EDID/01/01. Feedback: Input 01 EDID Upgrade OK By 01 EDID!</p>
<p>SetDevicePowerMode[XX].</p>	<p>Set the power mode: XX = 00-01 00: Follow Host 01: Always On</p>	<p>Set Device Power Mode To Follow Host! Set Device Power Mode To Always On!</p>
<p>SetGuiIP:xxx.xxx.xxx.xxx.</p>	<p>Set GUI IP to [xxx.xxx.xxx.xxx].</p>	<p>Example: SetGuiIP:192.168.0.18. Feedback: SETGUIIP:192.168.0.18 !</p>

SYSTEM OPERATIONS

<p>EDIDUpgrade[xx].</p>	<p>The serial port upgrades EDID data.</p> <p>[xx] represents the input port, the value can be 00, 01, 02, U1, U2, U3 and U4.</p> <p>[xx]=00-02 means to customize the EDID of the corresponding input port (EDID is switched to the custom EDID after customization, and will not be saved in the machine), 00 means to operate on all input ports, 01-02 means input 01-02.</p> <p>[xx]=U1-U4 means custom built-in EDID (can be saved in the machine and recalled at any time), only one built-in EDID can be customized, and the current EDID still used after the customization is completed will not switch to the customized EDID.</p> <p>After receiving the instruction, the machine will prompt to send the EDID file. The file format must be .bin within 10s (in order to ensure normal data reception, all HDBaseT must be disconnected before sending the instruction).</p>	<p>Input XX/User Define EDID Upgrade OK!</p>
<p>LOCK.</p>	<p>Lock front panel buttons.</p>	<p>Front Panel Locked!</p>
<p>UNLOCK.</p>	<p>Unlock front panel buttons.</p>	<p>Front Panel Unlock!</p>
<p>SetGuiIP_DHCPON.</p>	<p>Enable DHCP</p>	<p>GUI IP DHCP ON!</p>
<p>SetGuiIP_DHCPOFF.</p>	<p>Enable Static IP.</p>	<p>GUI IP DHCP OFF!</p>
<p>/+[X]:XXX.</p>	<p>Control the surrounding devices that connects to it.</p> <p>[X] represent the baud rate; it can be 1-7.</p> <p>1 - 2400, 2 - 4800, 3 - 9600, 4 - 19200, 5 - 38400, 6 - 57600, 7 - 115200</p> <p>XXX represents the ASCII code.</p>	<p>Example: /+3:123456.</p> <p>Feedback: 123456</p>
<p>SIGNALTRG[XX]MODE.</p>	<p>When setting the detection mode [xx] is 1, it is 5V detection. And when it is 2, it is TMDS detection.</p>	<p>Set Trigger Mode To 5V!</p>
<p>DSON.</p>	<p>Enable downscale.</p>	<p>Tx Loopout Down Scale On!</p>
<p>DSOFF.</p>	<p>Disable downscale.</p>	<p>Tx Loopout Down Scale Off!</p>

User Operation Guide

SYSTEM OPERATIONS

<p>CEC[I/O][port][command].</p>	<p>[I/O]: represent either video input ports or video output port the command will be sent to. I: means the CEC command will be sent to video input port, which are the USB-C and VIDEO (HDMI port). O: means the command will be sent to video output port, which are LOOPOUT (HDMI port) and the HDBT.</p> <p>[port]: specify the exact port of input/output to pass the command.</p> <p>When [I/O] is set to I, check the clarification if the [port] is set to below: 00: the command will be sent to both USB-C and VIDEO port. 02: the command will only be sent to the VIDEO port.</p> <p>When [I/O] is set to O, check the clarification if the [port] is set to below: 00: the command will be sent to LOOPOUT and HDBT. 01: the command will be sent to the display that connects to LOOPOUT port. 02: the command will be sent to the HDBT port, and finally will be send to the display that connects to the receiver remotely.</p> <p>[commands]: represents the exact CEC commands that need to be sent to. Please note, the CEC command must in hexadecimal format with a maximum length of 12 bytes.</p>	<p>Example: CECI010444A Feedback: CEC Input 01 Send Success!</p> <p>Example: CECO018004 Feedback: CEC Output 01 Send Success!</p>
<p>HDCPPAS.</p>	<p>Render the HDCP of the output follows the input. If the input has HDCP 2.2, the output will also have HDCP 2.2. If the input has HDCP 1.4, the output will have HDCP 1.4. If the input does not have HDCP, the output will not either.</p>	<p>HDCP Follow Input!</p>
<p>HDCPMAT.</p>	<p>Render the HDCP of the output follows the display.</p>	<p>HDCP Follow Output!</p>

SYSTEM OPERATIONS

<p>HDCPACT.</p>	<p>Render the HDCP of the output follows the input. If the input has HDCP, no matter which version it is, the output will have HDCP 1.4. If the input does not have HDCP, the output will not either.</p>	<p>HDCP Active!</p>
<p>HDCPOFF.</p>	<p>Turn off the HDCP of output. If it is turned off, there will not be any HDCP on the video output, regardless of whether the video input has HDCP or not.</p>	<p>Out HDCP DBG OFF!</p>
<p>SETMAC:AA-BB-CC-DD-EE-FF</p>	<p>Set a MAC address for the device.</p>	<p>Example: SETMAC:01-02-03-04-05-06 Feedback: MAC:01-02-03-04-05-06!</p>

User Operation Guide

SYSTEM OPERATIONS

Troubleshooting & Maintenance

Problems	Potential Causes	Solutions
Output image with snowflake	Bad quality of the connecting cable.	Try another high-quality cable.
	Fail or loose connection.	Make sure the connection is good
No output image when switching	No signal at the input / output end.	Check with oscilloscope or multimeter if there is any signal at the input/output end.
	Fail or loose connection.	Make sure the connection is good.
	The switcher is broken.	Send it to authorized dealer for repairing.
POWER indicator doesn't work or no respond to any operation	Fail connection of power cord.	Make sure the power cord connection is good.
Static becomes stronger when connecting the video connectors	Bad grounding.	Check the grounding and make sure it is connected well.
Cannot control the device by control device (e.g. a PC) through RS232 port	Broken RS232 port.	Send it to authorized dealer for checking.

Note: *If your problem still remains after following the above troubleshooting steps, please contact your local dealer or distributor for further assistance.*

DIAGRAM

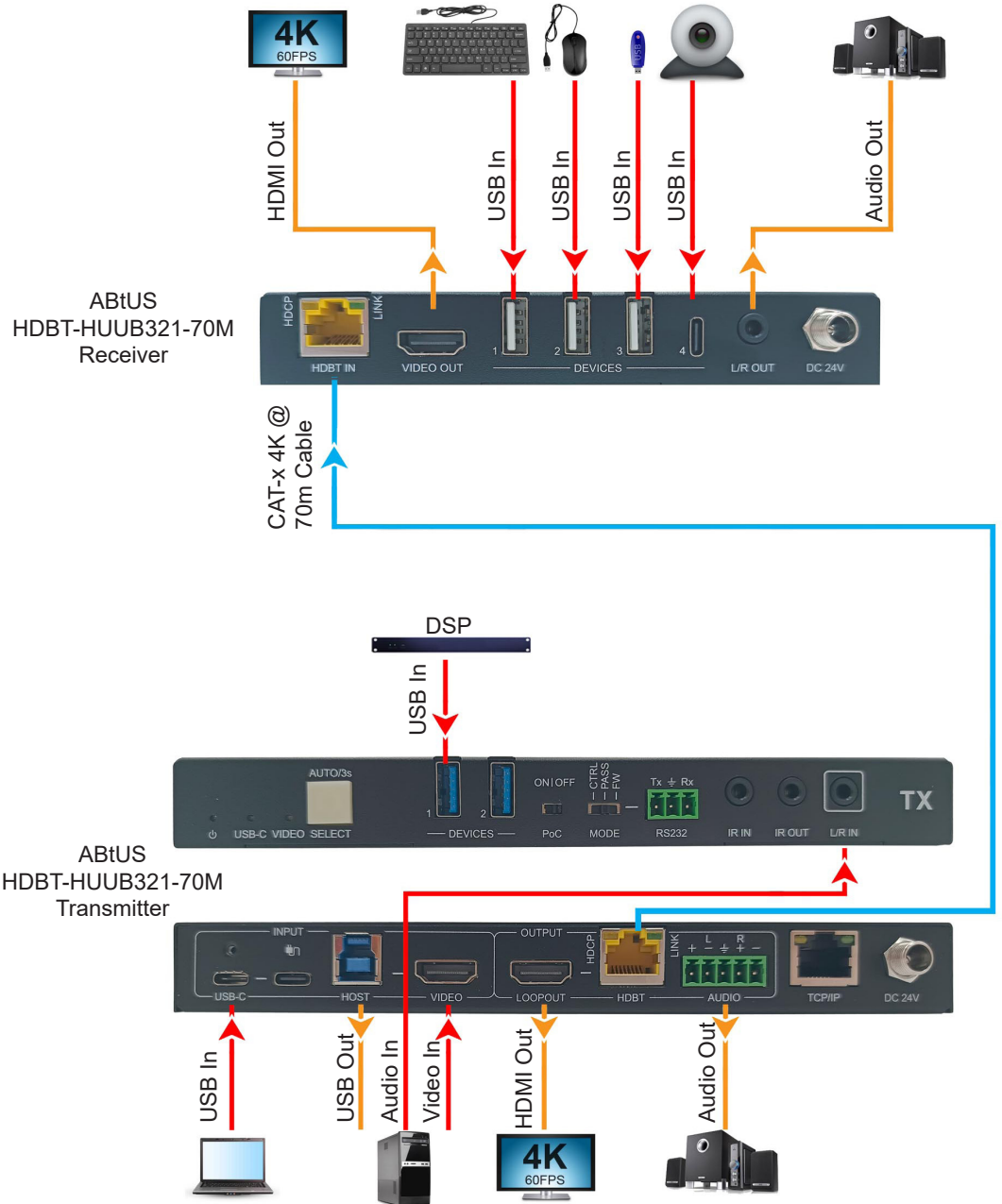

User Operation Guide

TECHNICAL SPECIFICATIONS

	Transmitter	Receiver
Video		
Input	1 x HDMI IN 1 x USB-C	1 x HDBT IN
Input Connector	1 x Type-A female HDMI 1 x USB Type-C	1 x RJ45
Input Resolution	Support up to 4K@60Hz 4:4:4	
Output	1 x HDBT OUT, 1 x LOOPOUT	1 x VIDEO OUT
Output Connector	1 x RJ45, 1 x Type-A female HDMI	1 x Type-A female HDMI
Output Resolution	Up to 4K@60Hz 4:4:4	
Audio		
Input	1 x L/R IN	-
Input Connector	1 x 3.5mm jack	-
Output	1 x Analog audio output	1 x L/R OUT
Output Connector	1 x 5-Pin terminal block	1 x 3.5mm jack
Audio Format	Supports PCM 2.0	
Frequency Response	20Hz ~ 20KHz, $\pm 3\text{dB}$	
Max Output Level	2.0Vrms $\pm 0.5\text{dB}$. 2V = 16dB headroom above -10dBV (316mV) nominal consumer line level signal	
THD+N	< 0.05% (-80dB), 20Hz~20KHz bandwidth, 1kHz sine at 0dBFS level (or max level)	
SNR	> 80dB, 20Hz-20kHz bandwidth	
Crosstalk Isolation	-70dB, 10kHz sine at 0dBFS level (or max level before clipping)	
L-R Level Deviation	< 0.3dB, 1kHz sine at 0dBFS level (or max level before clipping)	
Frequency Response Deviation	20Hz - 20kHz, $\pm 3\text{dB}$	
Output Load Capability	1K Ω and higher (Supports 10x paralleled 10K Ω loads)	
Stereo Channel Separation	> 70dB@1KHz	
Control		
Control Part	2 x USB DEVICES, 1 x RS232, 1 x IR IN, 1 x IR OUT, 1 x MODE Switch, 1 x PoC Switch, 1 x HOST, 1 x TCP/IP, 1 x USB-C	4 x USB DEVICE, 1 x RS232, 1 x IR IN, 1 x IR OUT, 1 x MODE Switch, 1 x PoC Switch, 1 x USB Power Switch

TECHNICAL SPECIFICATIONS

Control Connector	2 x USB 3.2 Gen1 Type-A, 1 x USB 3.2 Gen1 Type-B, 1 x 2-pin DIP Switch 2 x 3.5mm Jacks, 1 x 3-pin Terminal Block, 1 x USB-C	3 x USB 2.0 Type-A, 1 x USB 2.0 Type-C, 3 x 2-pin DIP Switch, 2 x 3.5mm Jacks, 1 x 3-pin Terminal Block
Bandwidth	18Gbps	
HDMI Standard	2.0	
HDCP Version	Input: HDCP 2.2, HDCP 1.4 compliant. Support HDCP management.	
Two-way PoC	Supported two-way 24V	
HDMI V2.0 Cable Length	4K@60Hz 4:4:4 ≤ 5m, 4K@30Hz 4:4:4 ≤ 10m, 1080p ≤ 15m	
Transmission Standard	HDBaseT	
Transmission Distance	4K@60 4:4:4 ≤ 40m; 4K@30 4:4:4 ≤ 70m, 1080p@60 4:4:4 ≤ 70m	
Operation Temperature	-5°C to +55°C (+23° to +131°F)	
Storage Temperature	-25°C to +70°C (-13°F to +158°F)	
Relative Humidity	10% to 90%, non-condensing	
Power Supply	DC 24V/1.5A	
Power Consumption	35.5W (Max)	28W (Max)
Dimension (W x H x D)	190mm x 21.7mm x 130mm	140mm x 21.5mm x 110mm
Net Weight	520g	360g

